

VINS



INSACCATRICI IDRAULICHE VERTICALI IN ACCIAIO INOX

- Carrozzeria e coperchio in acciaio inox
- Pistone acciaio inox
- Cilindro rimovibile in acciaio inox lucidato
- Velocità di uscita regolabile
- Avviamento e stop automatici con comando al ginocchio
- Tre imbui acciaio inox: ø 14, 22 e 30 mm
- Per macellerie, laboratori carni, salumifici, supermercati.

A richiesta

- Comando a pedale (in alternativa al comando a ginocchio)

UPRIGHT STAINLESS STEEL HYDRAULIC SAUSAGE FILLERS

- Stainless steel structure and cover
- Stainless steel piston
- Removable polished stainless steel piston
- Adjustable speed
- Automatic start/stop operation with knee control
- Three stainless steel funnels: ø 14, 22 and 30 mm
- For butcher's shops, meat processing centres, sausage factories, supermarkets

On request

- Foot control (optional device to knee control)

POUSSOIRS HYDRAULIQUES VERTICAUX EN ACIER INOX

- Carrosserie et couvercle en acier inox
- Piston en acier inox
- Cylindre démontable en acier inox poli
- Vitesse réglable
- Démarrage et arrêt automatiques par commande au genou
- Trois canules en acier inox: ø 14, 22 et 30 mm
- Pour boucheries, laboratoires de viande, fabriques de charcuterie, supermarchés

Sur demande

- Commande à pédale (au lieu de commande au genou)

HYDRAULISCHE VERTIKAL-WURSTFÜLLER AUS EDELSTAHL

- Gehäuse und Deckel aus Edelstahl
- Edelstahlkolben
- Abnehmbarer Cylinder aus poliertes inox stahl
- Automatischer Start und Stopp mit Knieschalter
- Schneller Kolbenrücklauf
- Ausstattung drei Edelstahltrichter: Ø 14, 22 und 30 mm
- Äußerst genaue Fleisch verarbeitende Betriebe, Wurstfabriken, Supermärkte,...

Auf anfrage

- Pedalsteuerung (zubehör anstatt der kniesteuerung)

EMBUTIDORAS HIDRÁULICAS VERTICALES DE ACERO INOX

- Bastidor y tapa en acero inox
- Pistón inox
- Cilindro removible de acero inoxidable lúcido
- Velocidad regulable
- Arranque y parada automáticos con mando de rodilla
- Equipadas con tres embudos inox: ø 14, 22 e 30 mm
- Para carnicerías, talleres de procesamiento de carnes, fábricas de embutidos, supermercados.

Bajo pedido

- Mando de pedal (en alternativa de mando de rodilla)

CARATTERISTICHE TECNICHE - TECHNICAL SPECIFICATIONS - TECHNISCHE DATEN - CARACTÉRISTIQUES - ESPECIFICACIONES

		VINS/22	VINS/32	VINS/45
Capacità - Capacity - Capacité - Fassungsvermögen - Capacidad	l (kg)	22 (19)	32 (27)	45 (38)
motore, motor, Motor, moteur, motor	kW (HP)	0,52 (0,70)	0,52 (0,70)	0,52 (0,70)
Peso netto - Net weight - Poids net - Nettogewicht - Peso neto	kg	119	125	135
H	mm	1188	1188	1264
A	mm	568	568	568
B	mm	518	518	518

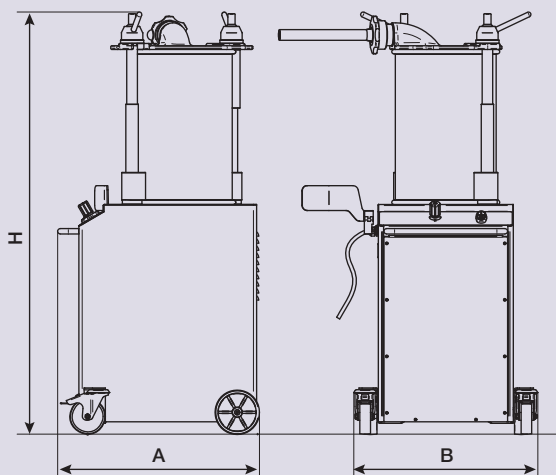

Macchina conforme alle norme CE in materia di igiene e di sicurezza.

The machine complies with CE standards in terms of hygiene and safety.



Biro France

7 bis Boulevard Robert Thiboust 77700 Serris

☎ : 01 64 63 35 00 • 📠 : 01 64 63 35 01

@ : info@biro.fr • www.biro.fr

MADE IN ITALY